

Shrink Wrappers-Tunnel

Frozen fish shrink wrapper.
Model ZEF-SL.



OPERATION

Specially designed for its installation on ships or at maritime ports. Frozen fish blocks are sprayed with special additives and disinfectants with the machines described above. The frozen block is fully sealed with a central and side plastic welds so that it can be stored in the ship's or port's freezing chambers.

TECHNICAL FEATURES

Monobloc construction to easily move the machine.

Features wheels with brakes to transport the machine.

Shrink wraps with polyethylene film.

Electronic temperature control in the shrink wrap and welding tunnel.

Manual controls and fully automatic operation.

Top quality materials: OMRON automation system, FESTO pneumatic system, TELEMECANIQUE electrical devices. TELEMECANIQUE.

PRODUCTS AND MARKET SECTORS

Food products: frozen fish blocks.

Shrink Wrappers-Tunnel

Frozen fish shrink wrapper.
Model ZEF-SL.

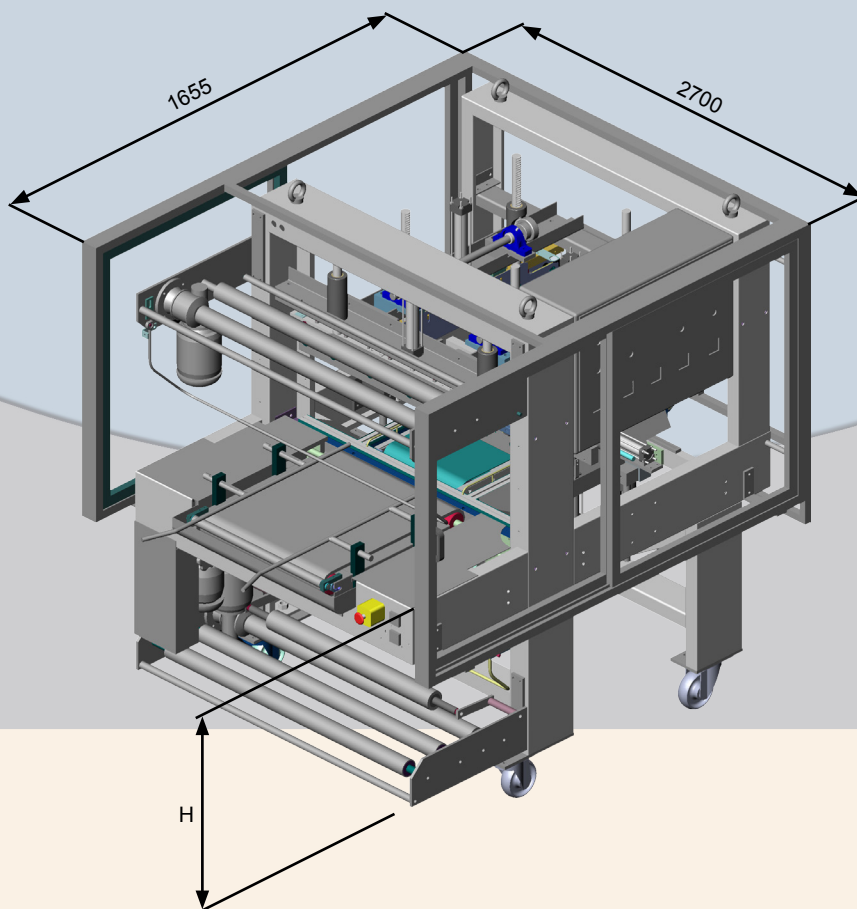

Voltage	220v or 380v
Power	5 Kw
Weight	700 Kg
Air consumption	100 l/min
Air pressure	6 atm.
Film thickness	50-100 microns
Production	12-14p/min according to product



ZORPACK

Polígono Industrial Comarca-2, calle B, Nº 20
31191 Ezquiroz (Navarra)
Tel.: +34 948 303 005
Fax: +34 948 302 644
E-mail: zorpack@zorpack.com
www.zorpack.com