

Shrink Wrappers-Tunnel

Shrink wrapping machine with sequential program.
Model ZEA-90 PS.



OPERATION

The product is placed on the machine's input tray at 90°. The machine has a braking, decompression and pushing cylinder assembly that separates the product in the requested formats. A sequential program will be used, according to the bundling operation of the machine, pushing the first row and then pushing all other rows required to complete the bundle.

TECHNICAL FEATURES

Monobloc construction to easily move the machine.

Shrink wraps with polyethylene film.

Electronic temperature control in the shrink wrap and welding tunnel.

Manual controls and fully automatic operation.

Braking system for different products.

Top quality materials: OMRON automation system, FESTO pneumatic system, TELEMECANIQUE electrical devices.

- Note: we will install a pneumatic positioning system to arrange the products in 1 or 2 rows, according to the line production requirements. This will prevent having to push the package rows, reducing the operation to the sequential program to half the production rate.

PRODUCTS AND MARKET SECTORS

Wide variety of food products: canned vegetables, canned meat, canned fish, coffee, flour, rice, legumes, sugar, yoghurt, salt, pickled foods, mushrooms, milk, cookies, ice cream, olives, semolina, pâté, etc.

Non-food products: paint, soap cases, aerosols, chemist's, etc.



Shrink Wrappers-Tunnel

Shrink wrapping machine with sequential program.

Model ZEA-90 PS.

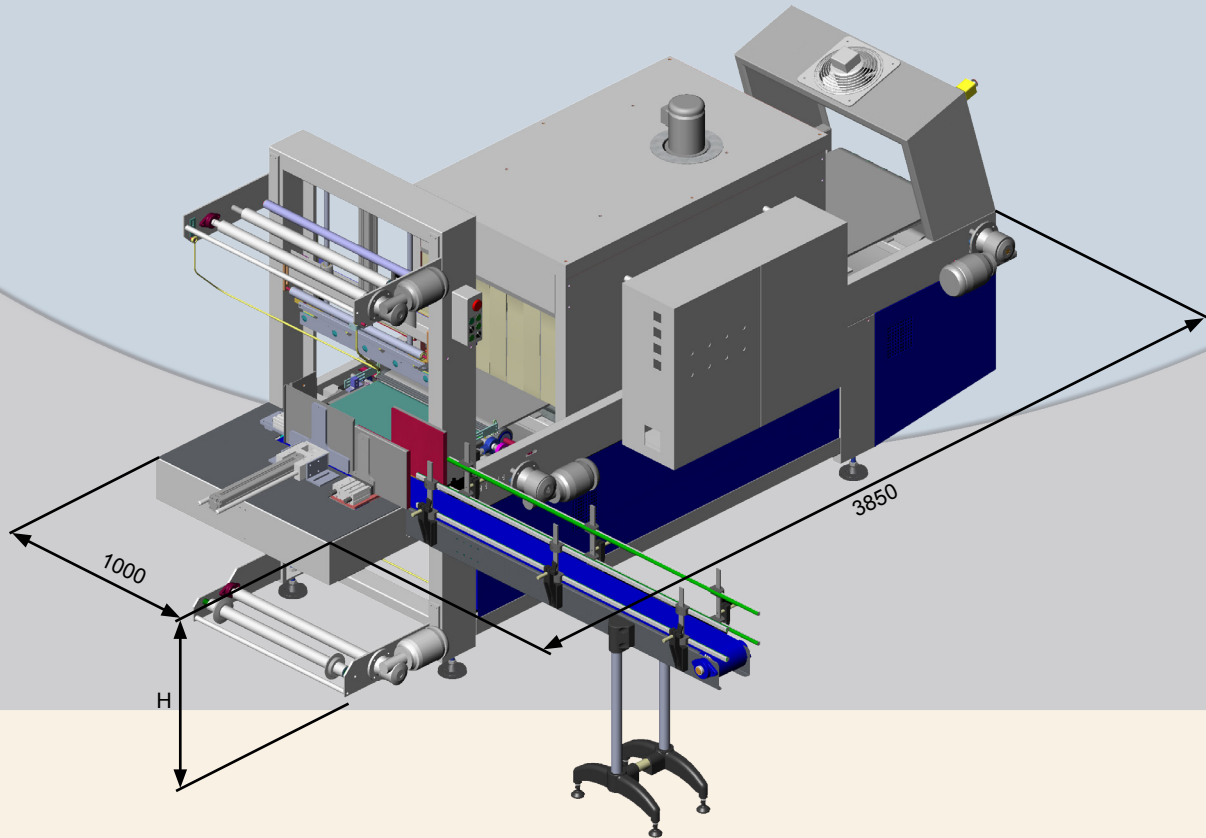

Voltage	220v or 380v
Power	20 Kw
Weight	1 100 Kg
Air consumption	100 l/min
Air pressure	6 atm.
Film thickness	50-100 microns
Production	12-14 p/min according to product-bundle size



ZORPACK

Polígono Industrial Comarca-2, calle B, N° 20

31191 Ezquiroz (Navarra)

Tel.: +34 948 303 005

Fax: +34 948 302 644

E-mail: zorpack@zorpack.com

www.zorpack.com