

# Wrap Around Packers

Low production rate Wrap Around Packer (8-10 boxes/min):  
Model ZACB.



## OPERATION

The input system changes according to the product, production and bundling requirements. The suction pads of the supply system are placed on the base of the cardboard sheet, positioning the raised side panels between the chain folding elements. The feeding system moves the bundle to the opened box/tray, which is formed according to the type of product. The flaps are glued with hot glue using a Hot Melt unit. The lower (for boxes/trays) and upper trainer (only for boxes) folds all flaps of the box/tray.

## TECHNICAL FEATURES

Bundles the products in Wrap Around boxes or on high-edge trays.  
Format changes are controlled with flywheels with built-in counters.  
Manual controls and fully automatic operation.  
Feeding system used to move the bundle to the Packer.  
Touch-screen used to adjust or add new formats.  
Vertical cardboard sheet feeder.  
Top quality materials: OMRON automation systems, FESTO pneumatic systems, TELEMECANIQUE electrical devices, MELER or MELTON gluing equipment.

## PRODUCTS AND MARKET SECTORS

Food: Canned vegetables, canned meat, canned fish, pickled foods, mushrooms, olives.  
Drinks: Water, fruit juice, oil, dairy products, soft drinks, milkshakes, soda water, energy drinks, alcoholic beverages, liquid yoghurt, beer, vinegar, sauces, chemist's blisters and containers, etc.



# Wrap Around Packers

Low production rate Wrap Around Packer (8-10 boxes/min):  
Model ZACB.

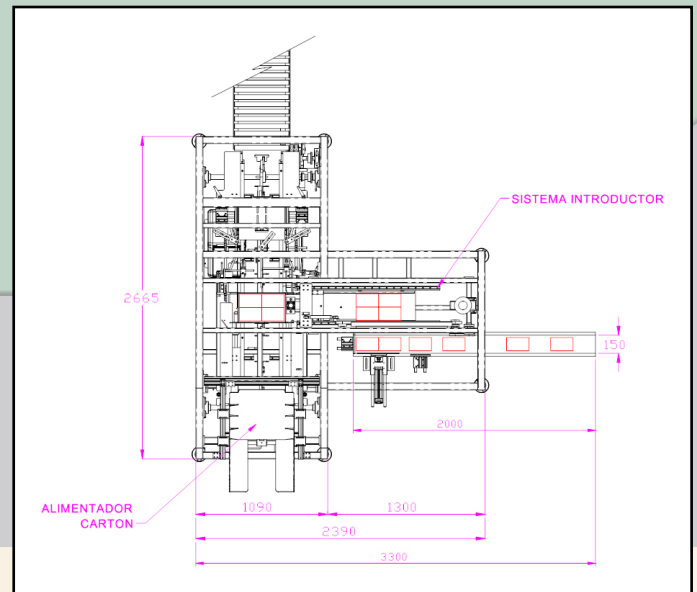
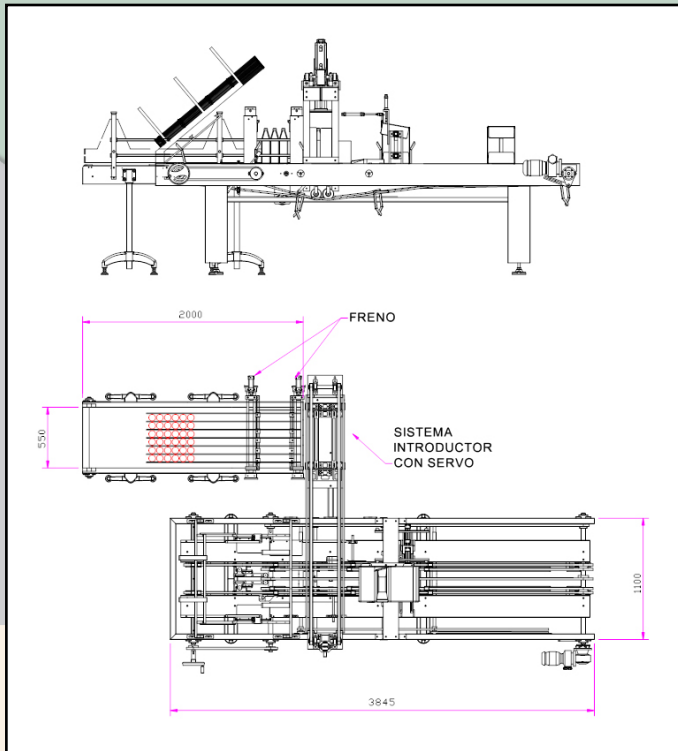

Voltage	220v or 380v
Total power	6 Kw
Weight	900Kg
Air consumption	100 l/min
Air pressure	6 atm
Film thickness	50-100 microns
Production of boxes or trays	10-12 p/min, according to product-bundle size



**ZORPACK**

Polígono Industrial Comarca-2, calle B, N° 20  
31191 Ezquiroz (Navarra)  
Tel.: +34 948 303 005  
Fax: +34 948 302 644  
E-mail: zorpack@zorpack.com  
www.zorpack.com