

Wrap Around Packers

Wrap Around Packer for fruit and vegetable produce (100 boxes/min).
Model ZAH.



OPERATION

The input system bundles the products with a pneumatic system. 250g containers are processed at the input and 500g and 1000g containers on a parallel input.

The suction pads of the supply system are placed on the base of the cardboard sheet, positioning the raised side panels between the chain folding elements. The feeding system moves the bundle to the opened box, which is formed according to the type of product.

The cylinder assembly folds the flaps of the box so it can be stacked. Boxes are delivered in stacked form (two heights).

CARACTERÍSTICAS TÉCNICAS

Bundles special boxes for the fruit and vegetable produce sector.

Format changes are controlled with flywheels with built-in counters.

Manual controls and fully automatic operation.

Feeding system used to move the bundle to the Packer.

Touch-screen used to adjust or add new formats.

Vertical cardboard sheet feeder.

Top quality materials: OMRON automation systems, FESTO pneumatic systems, TELEMECANIQUE electrical devices, MELER or MELTON gluing equipment.

PRODUCTS AND MARKET SECTORS

Fruit and vegetable produce sector; strawberry, blueberry, kiwi, grape, pear and apricot boxes, packaged with a FLOW pack machine.



Wrap Around Packers

Wrap Around Packer for fruit and vegetable produce (100 boxes/min).
Model ZAH.

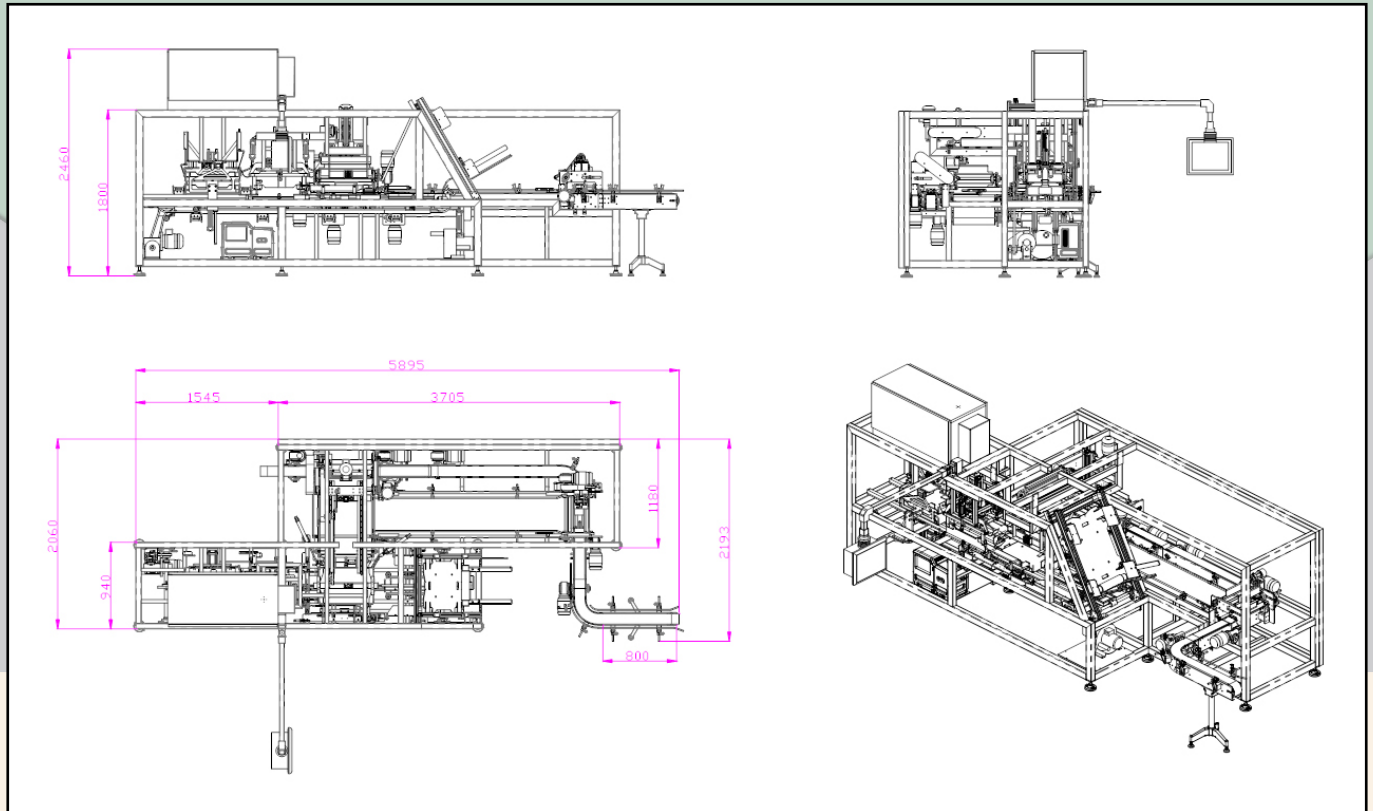

Voltage	220v or 380v
Total power	8 Kw
Weight	900Kg
Air consumption	100 l/min
Air pressure	6 atm
Film thickness	50-100 microns
Production	100-120 jars/min



ZORPACK

Polígono Industrial Comarca-2, calle B, Nº 20
31191 Ezquiroz (Navarra)
Tel.: +34 948 303 005
Fax: +34 948 302 644
E-mail: zorpack@zorpack.com
www.zorpack.com